

# SLIM 190ml(200/202X402) SPECIFICATIONS

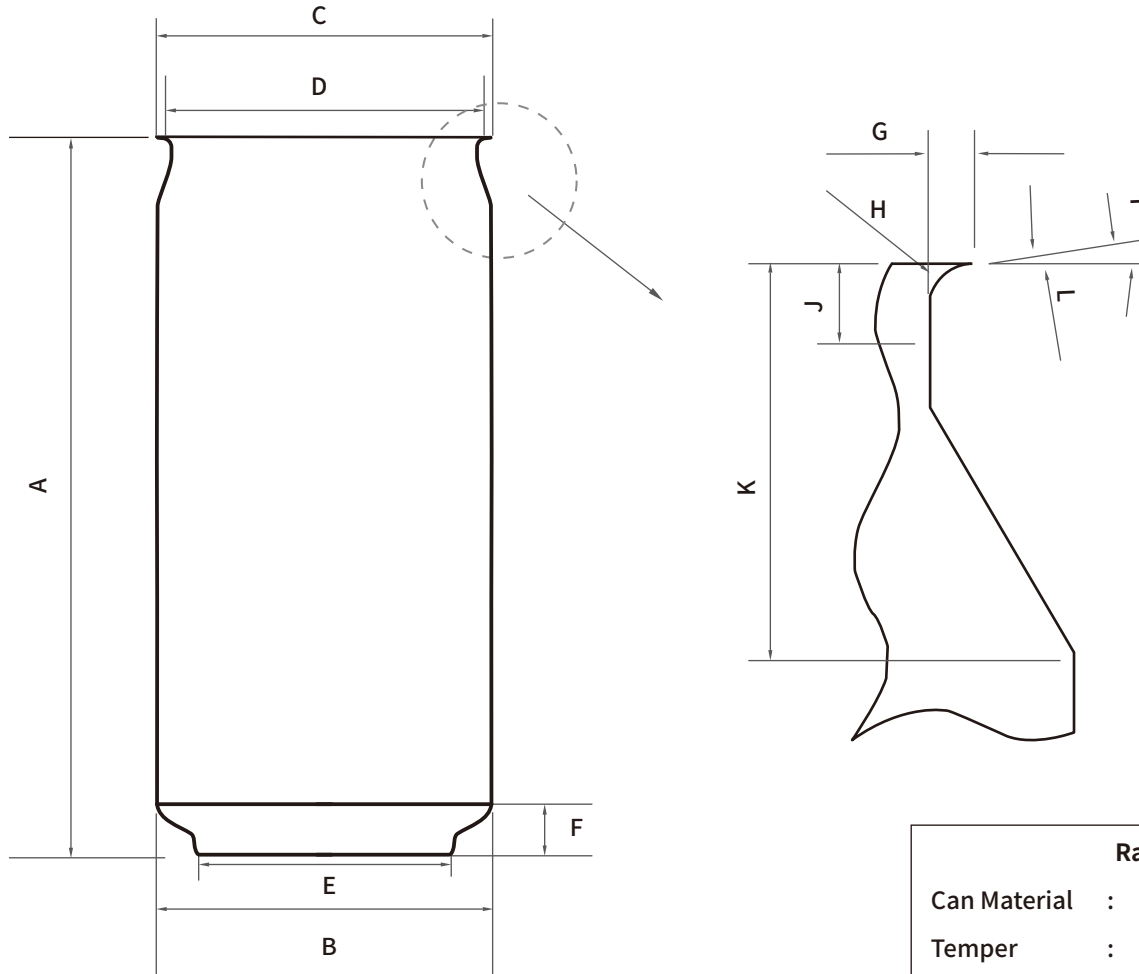

## TWO-PIECE ALUMINUM CAN



| Item | Description                  | Unit | Specification | Tolerance |
|------|------------------------------|------|---------------|-----------|
| A    | Finished Can Height<br>成品罐高度 | mm   | 104.5         | ±0.25     |
| B    | Can Body Diameter<br>罐体直径    | mm   | 53.0          | REF       |
| C    | Flange Diameter<br>翻边直径      | mm   | 54.70         | REF       |
| D    | Neck Plug Diameter<br>缩颈内径   | mm   | 50.00         | ±0.25     |
| E    | Base Diameter<br>底圆直径        | mm   | 43.0          | REF       |
| F    | Dome Depth<br>圆顶深度           | mm   | 8.30          | ±0.30     |
| G    | Flange Width<br>翻边宽度         | mm   | 2.10          | ±0.25     |
| H    | Flange Radius<br>翻边半径        | mm   | 1.524         | REF       |
| I    | Flange Angle<br>翻边角度         |      | 0-7°          |           |
| J    | Seaming Clearance<br>密封间隙    | mm   | 3.0           | REF       |
| K    | Neck Height<br>颈部高度          | mm   | 9.80          | REF       |
| L    | Flange Thickness<br>翻边厚度     | mm   | 0.16          |           |

| Raw Material                       |                                  |
|------------------------------------|----------------------------------|
| Can Material : Aluminum alloy 3104 | Interior coating : Epoxy         |
| Temper : H19                       | Overflow Capacity : 210±2.0ml    |
| Coil thickness : 0.270±0.005mm     | Axial Load : 1KN min.            |
|                                    | Buckling Pressure : 610 KPa min. |

|  |   |              |                         |  |
|--|---|--------------|-------------------------|--|
|  | Issued Date: Feb. 17 <sup>th</sup> 2024 | Approved by: | Copyright@<br>2023-2025 | 山东今洲健康实业有限公司<br>Shandong Jinzhou Health<br>Industry Co.,Ltd. |
|  | Version Number: 202402                  | Customer:    |                         |  |

# SLIM 190ml(200/202X402) SPECIFICATIONS



## TWO-PIECE ALUMINUM CAN-PACKAGING

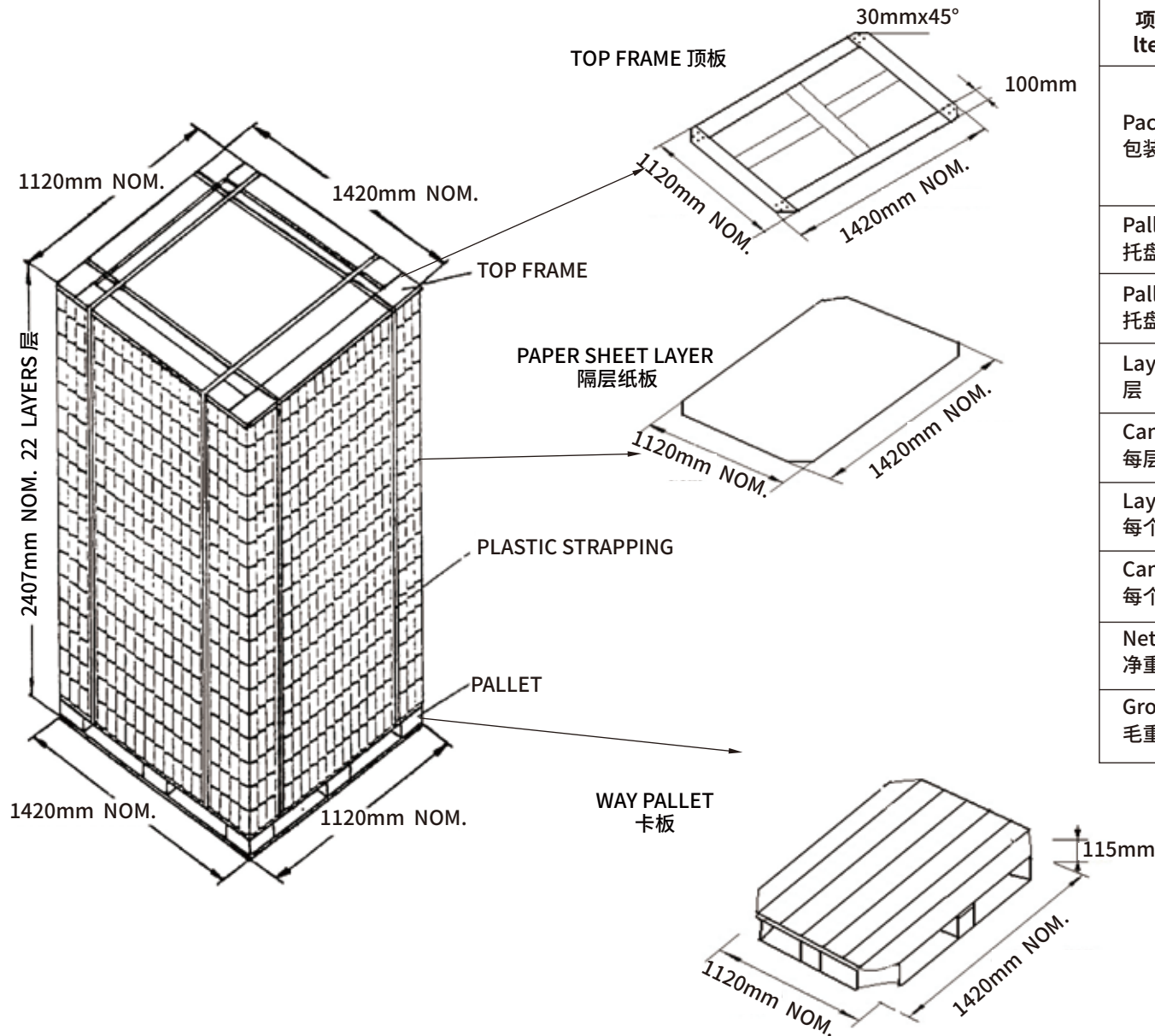

| 项目<br>Item                     | 苗条 190ml<br>Slim 190ml  |
|--------------------------------|---|
| Packaging Material<br>包装材料     | Pallet, top frame,<br>paper sheet,<br>plastic film,<br>Strap, label |
| Pallet Type<br>托盘类型            | standard export plywood pallet                                      |
| Pallet Size<br>托盘尺寸(L x W x H) | 1420×1120×2407mm  |
| Layer<br>层                     | Paper sheet   |
| Cans Per Layer<br>每层罐头数        | 598   |
| Layers Per pallet<br>每个托盘的层数   | 22  |
| Cans Per Pallet<br>每个托盘的罐子     | 13156   |
| Net Weight<br>净重               | 115kg Apprex.   |
| Gross Weight<br>毛重             | 145kg Apprex.   |